

strapex

Product securing during transportation for Metal Service Centres

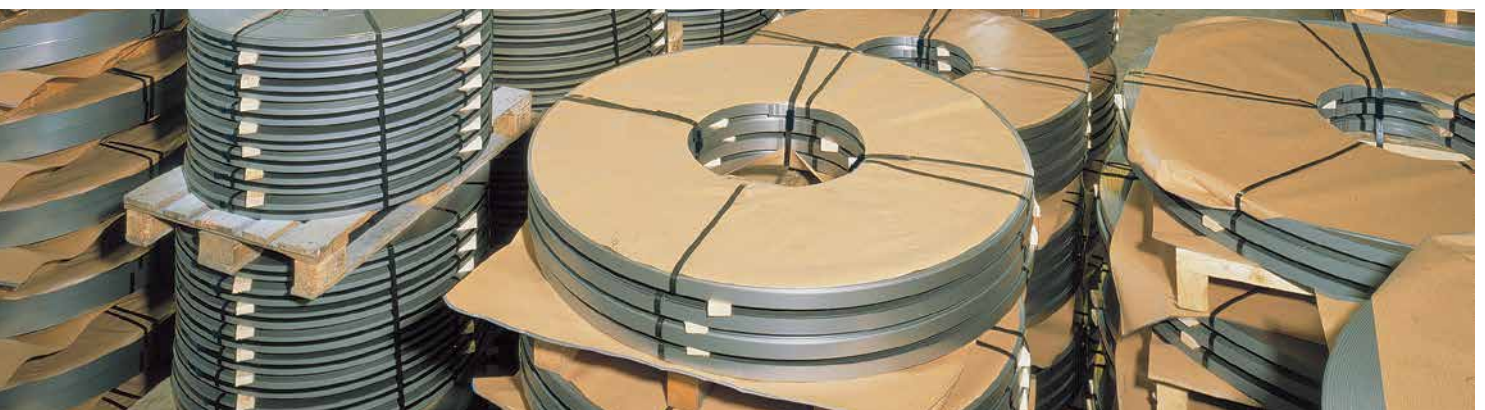

ORGAPACK
TECHNOLOGY

System solutions for Metal Service Centres

For new installations or for integration into existing packaging lines



Customer benefits

- Comprehensive advisory service
- Professional project documentation
- Development of your machine on the most modern 3D-CAD work stations
- Assembling and acceptance test in-house
- Integration and commissioning in your product line
- User-friendly operating instructions
- Training of your service and maintenance personnel

The right machine

Due to the flexibility of their machine construction programme, Strapex can offer tailor-made solutions for customers individual applications.

The right strap

A comprehensive range of plastic strap (PET) and steel strap each with their own characteristics to ensure that strap and equipment are always the best possible combination!

Worldwide Sales and Service

You will receive expert advice on choosing the right solution and service package together with the guaranteed availability of spare parts.

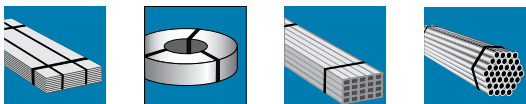
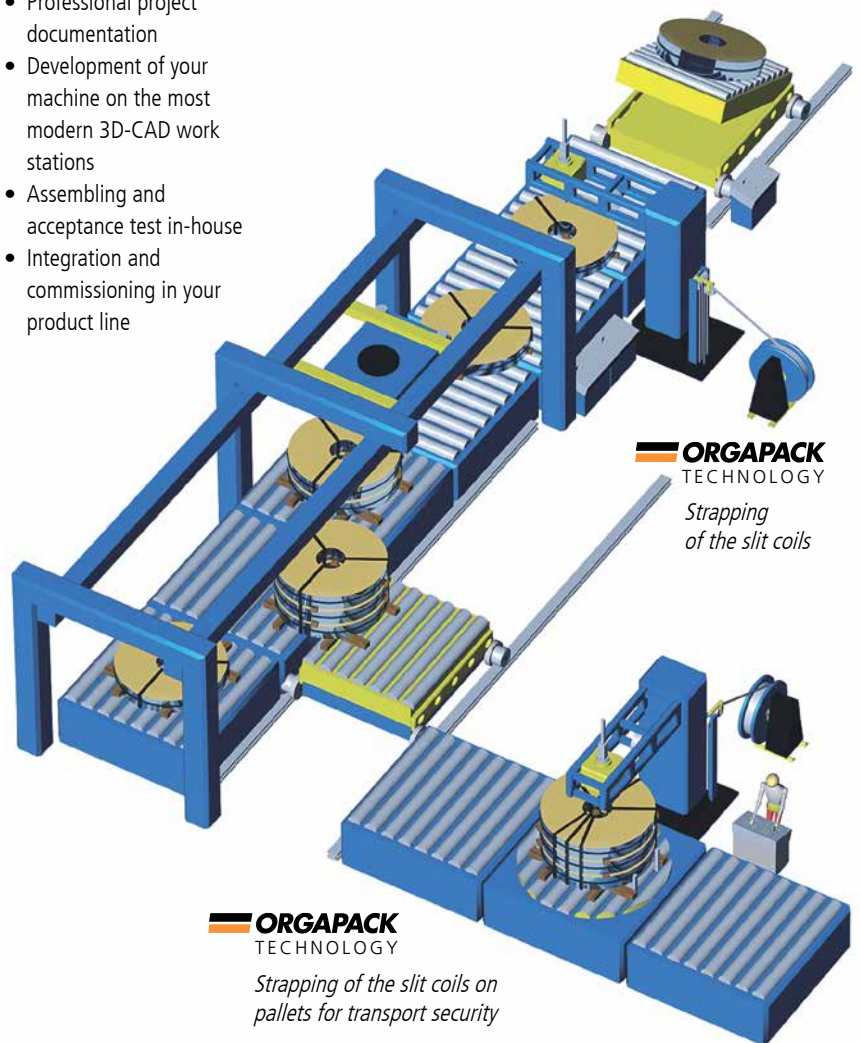

Flexible solutions . . .



. . . with plastic strap: Weld seal

- For high tensile polyester strap



. . . with steel strap: Notched seal

- No metal seals necessary
- For flat and round packages



. . . with steel strap: Weld seal

- No protection gas necessary
- Preferred for small, hexagonal bundles and for slit coils

Strapping system solutions

Metal sheets

With high tensile polyester strap

- 1 Transverse strapping with laterally movable machine
- 2 Longitudinal strapping

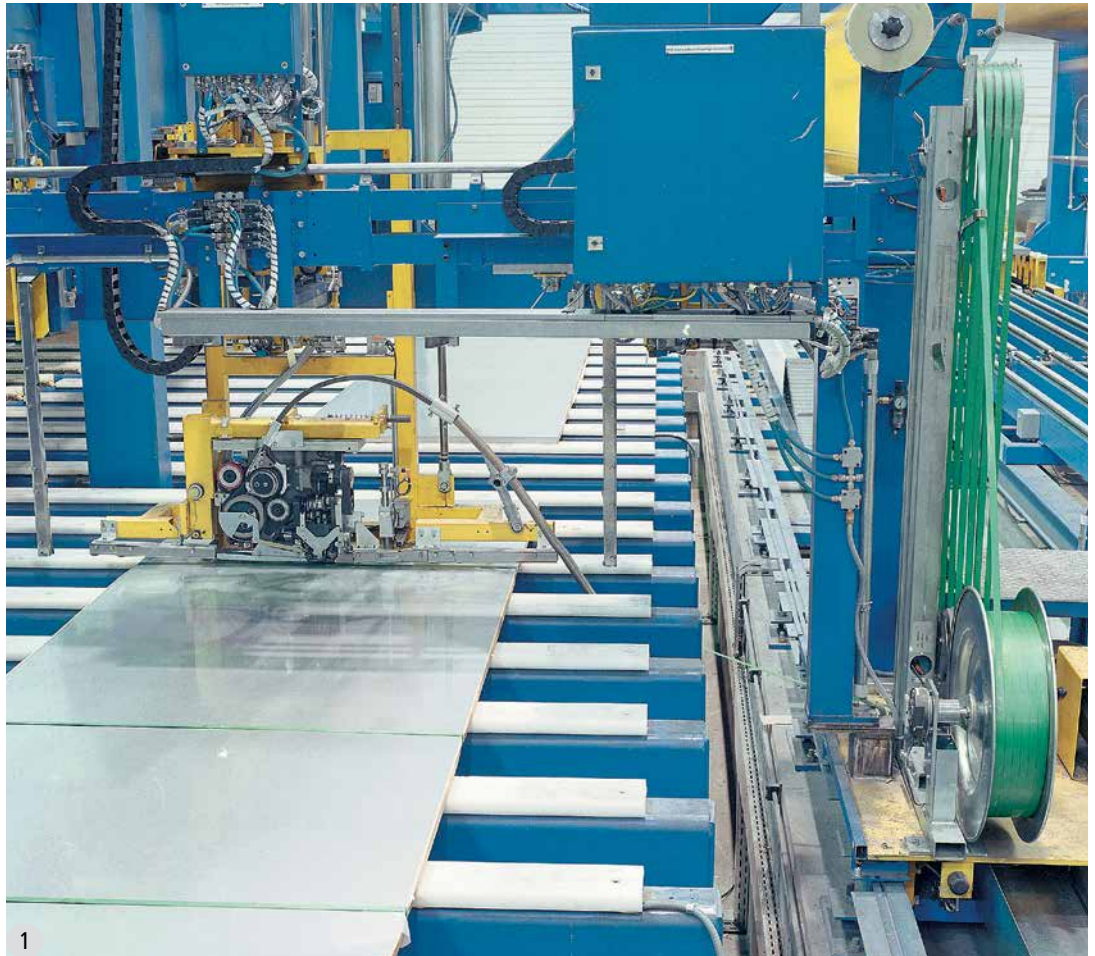

Strapping system solutions

Metal sheets

With steel strap

1
Transverse strapping
of packs of metal sheets

Options:

For steel and polyester
strap

- Top corner edge
applicator
- Bottom runner
applicator

2
Longitudinal strapping
of packs of metal sheets

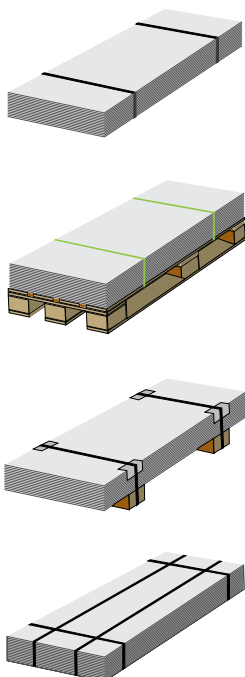

Slit coils

Strapping of slit coils

- 1
Strapping of slit coils with
integrated turntable
- 2
Securing of slits coils on
special pallets (skids)



Tubes and profiles

Flexible solutions

- 1 Strapping bundles of tubes
- 2 Strapping hot drawing profiles
- 3 Strapping bundles of profiles with bottom runners
- 4 Packaged insulation tubes



System solutions

Semi-Automatic and manual solutions for stationary and mobile strapping

With polyester or steel strap

1
Semi-Automatic strapping of packs of metal sheets



With steel strap

2
Strapping of round packages with pneumatic hand tools



3
Strapping of flat packages with hand tool (manual tensioning and sealing)



With polyester strap

4, 5
Mobile strapping of flat packages with battery-powered hand tools



Make your products feel safe



Own development and manufacturing



Proven solutions for various industry segments



Worldwide sales and service network

www.strapex.com